

Actuators

- A mechanism that converts energy into mechanical motion
 - Hydraulic
 - Pneumatic
 - Electric
 - Magnetic
 - Mechanical
 - Bio-hybrid
 - Light-driven
 - Thermal

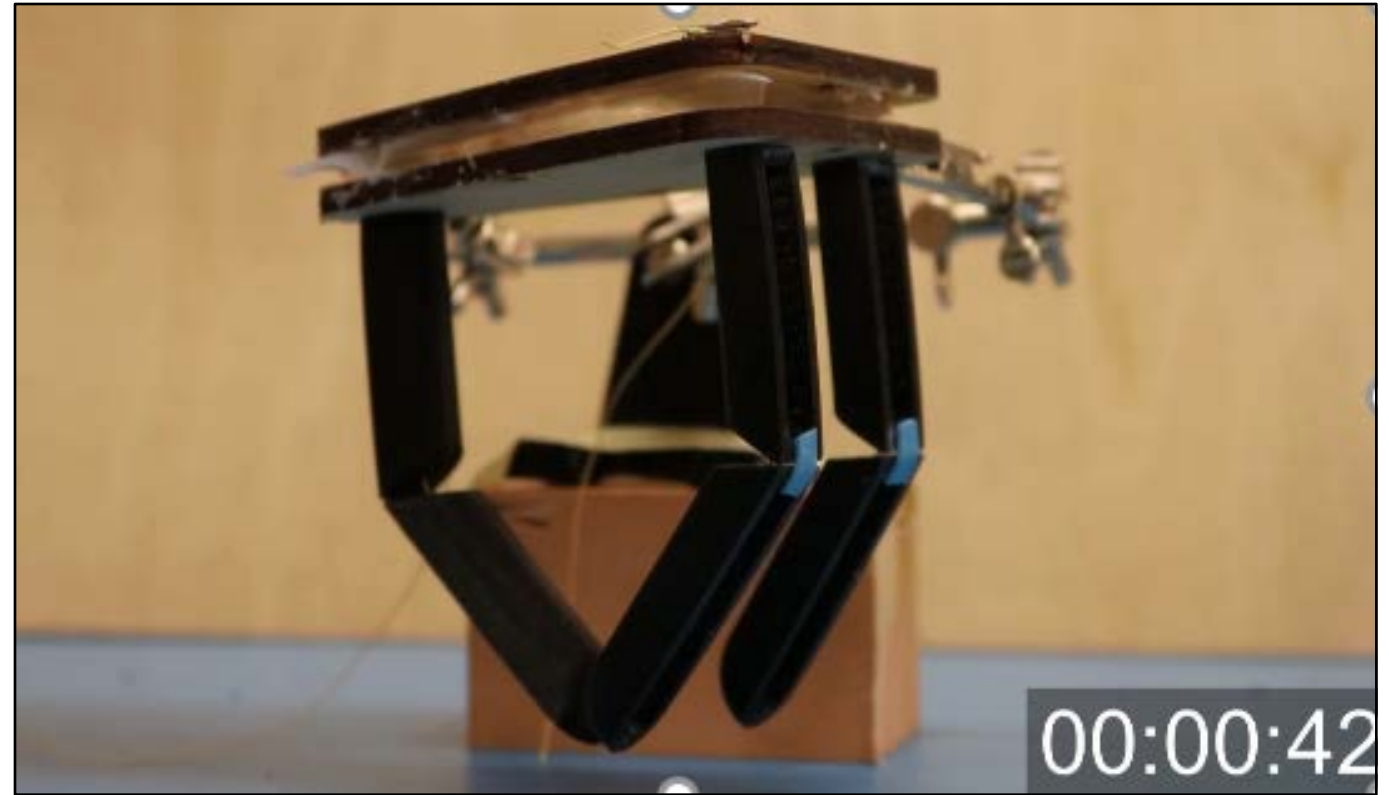

Actuators

- A mechanism that converts energy into mechanical motion



Brushed DC motor

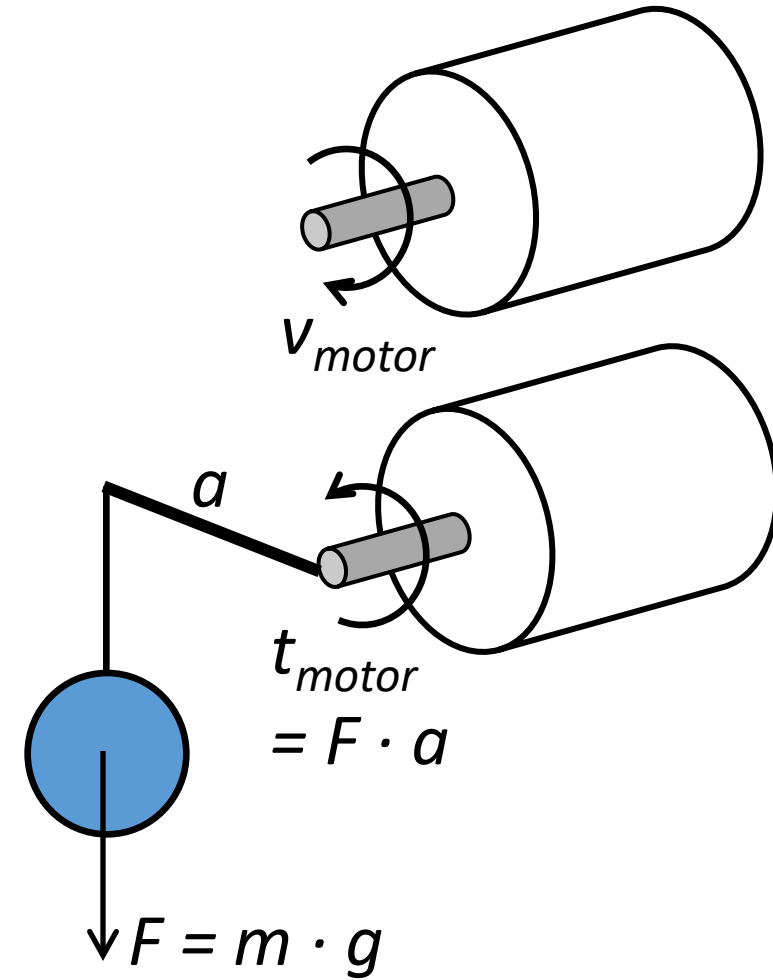
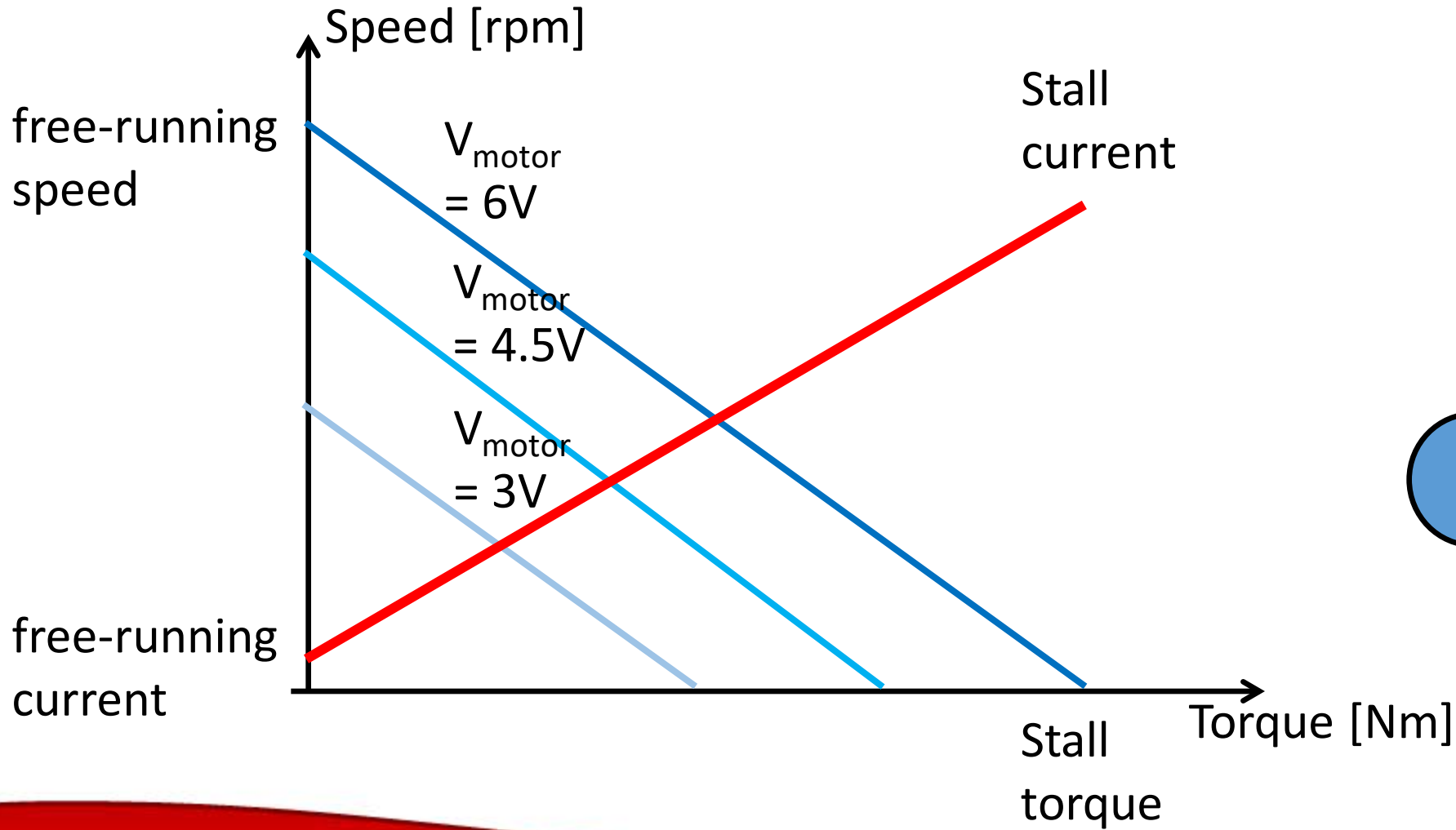

Brushed DC motor

permanent magnets

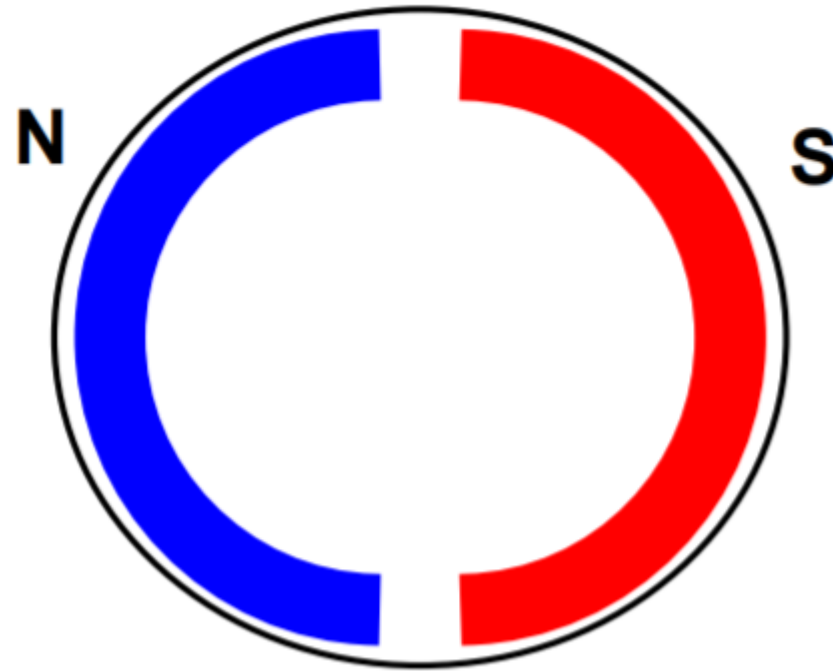

Brushed DC motor

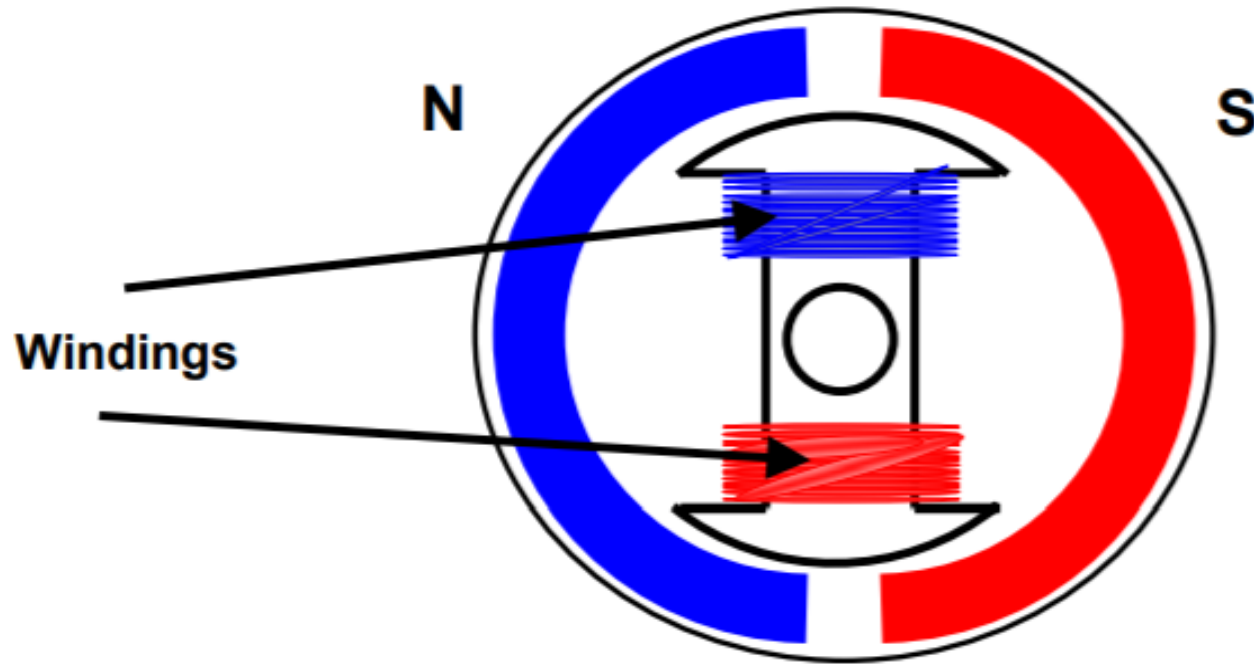

Brushed DC motor

- Ampere's Right Hand Rule

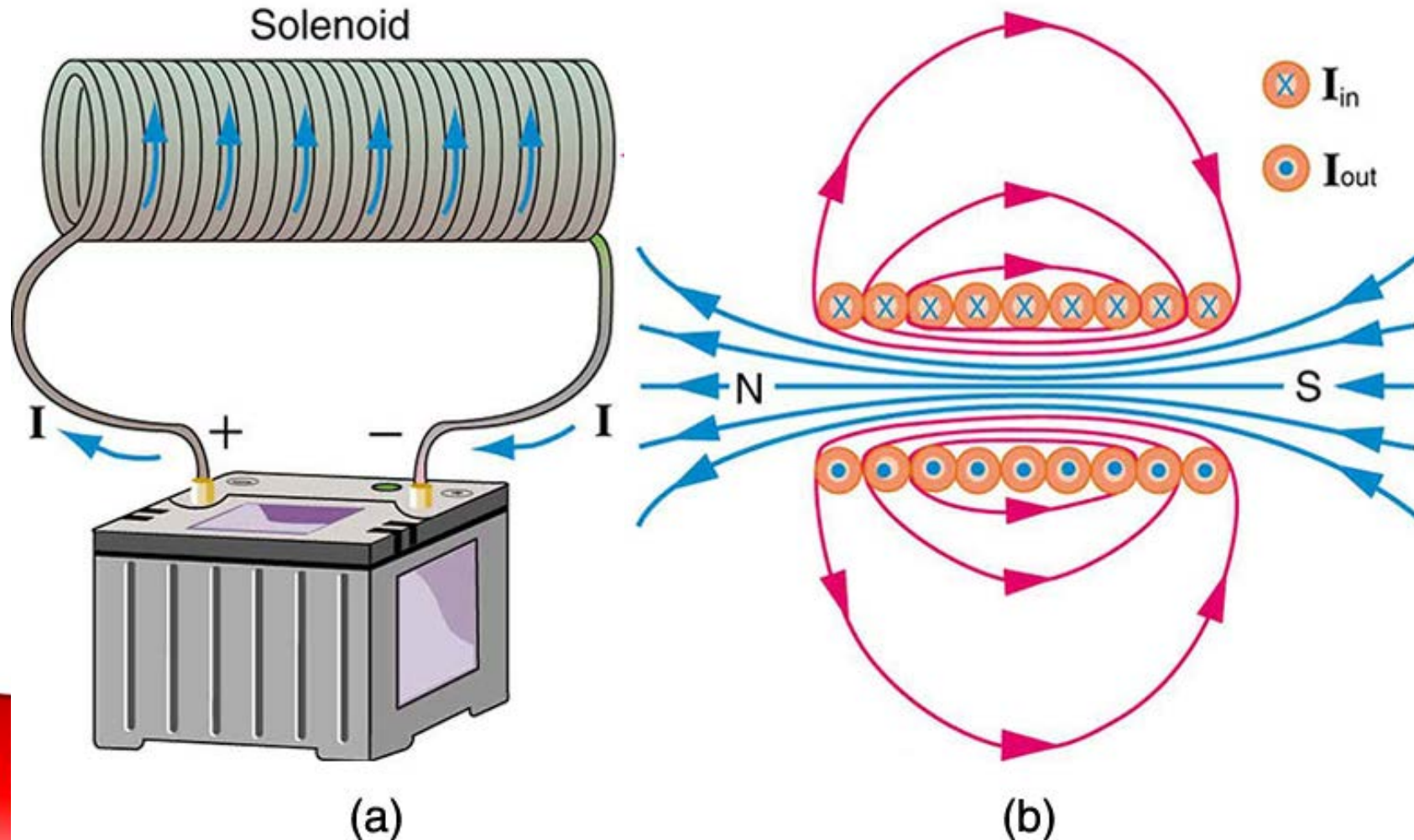

Brushed DC motor

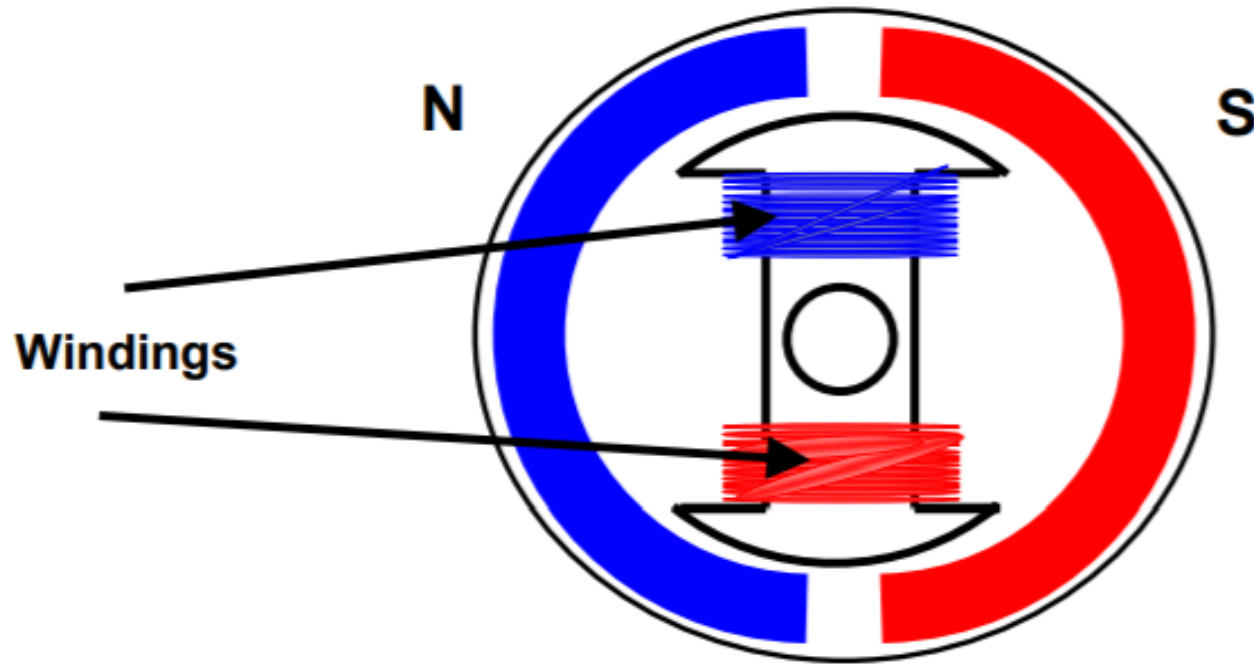

Brushed DC motor

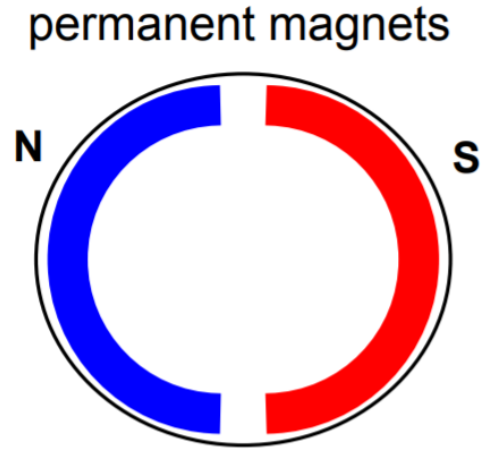
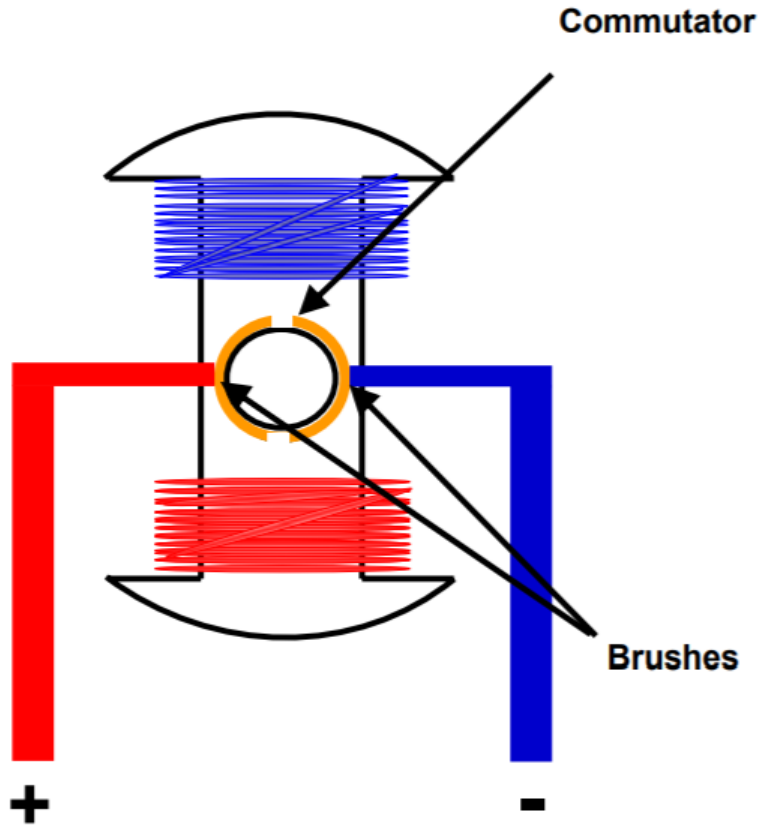

Brushed DC motor

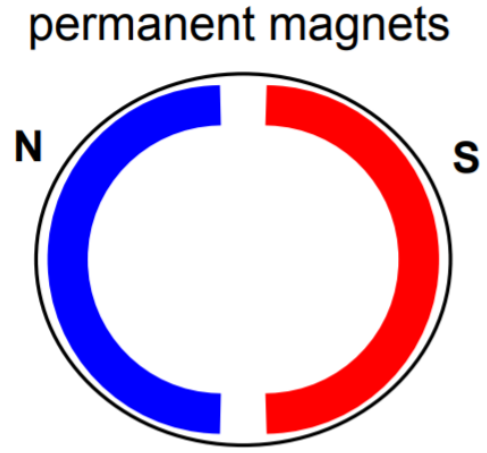
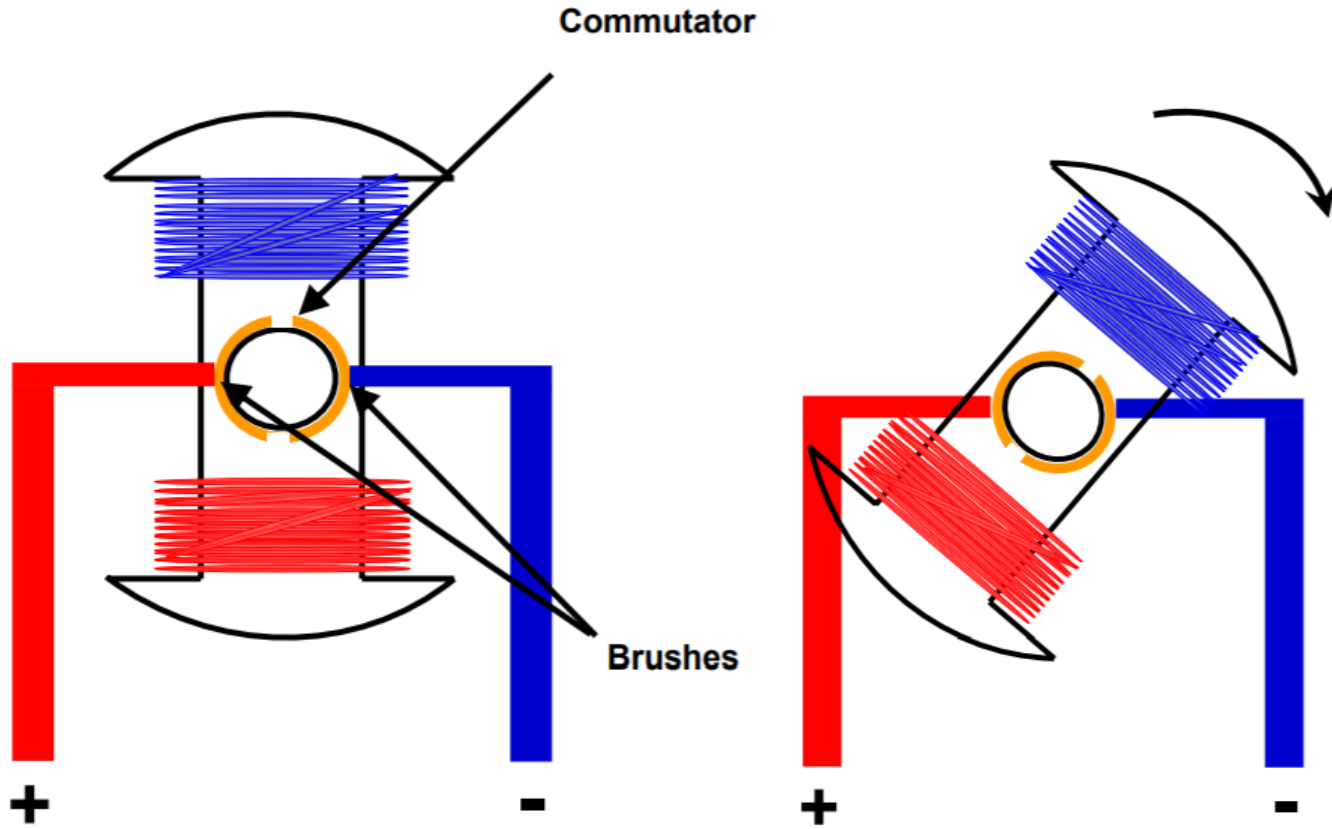

Brushed DC motor

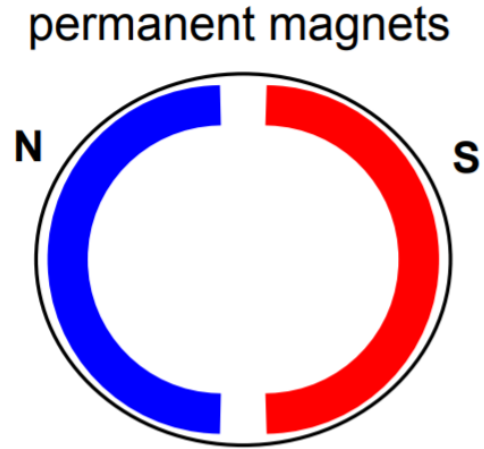
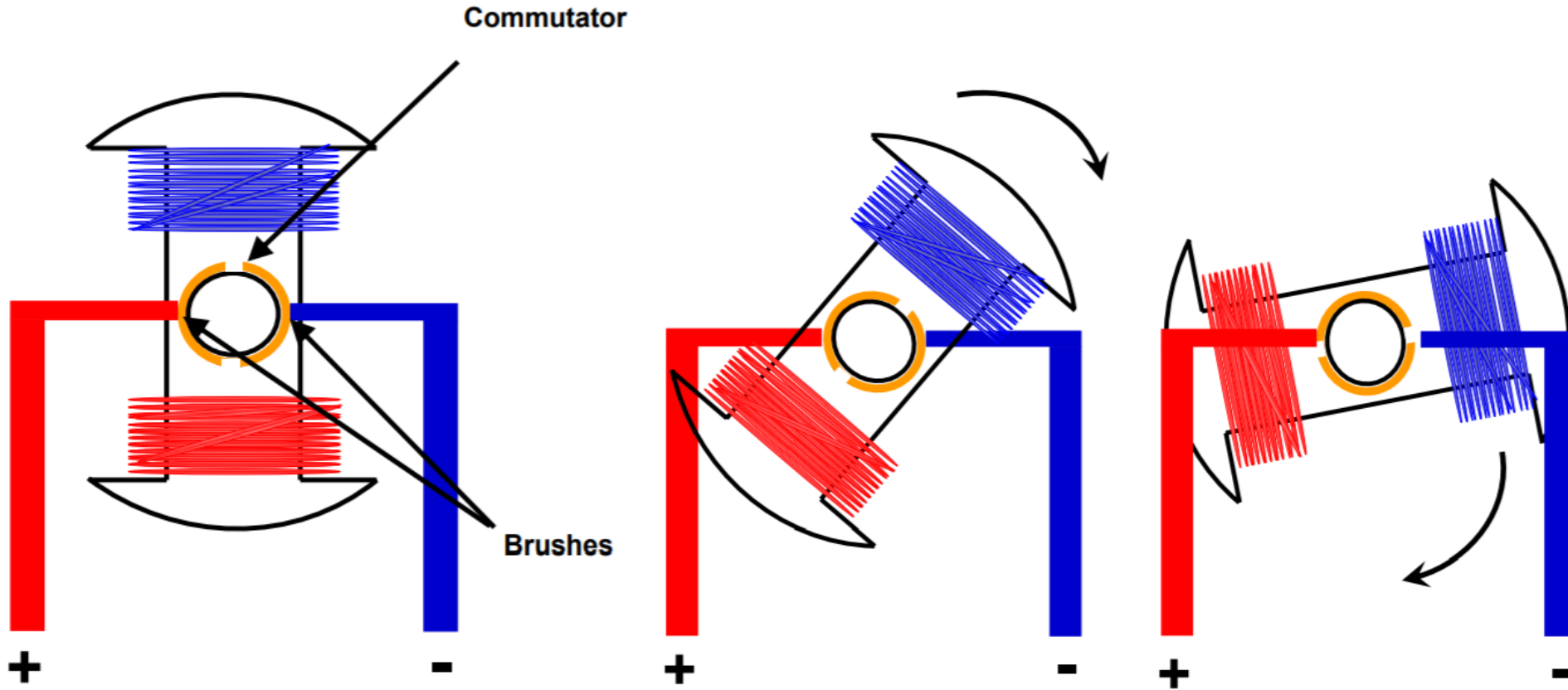

Brushed DC motor

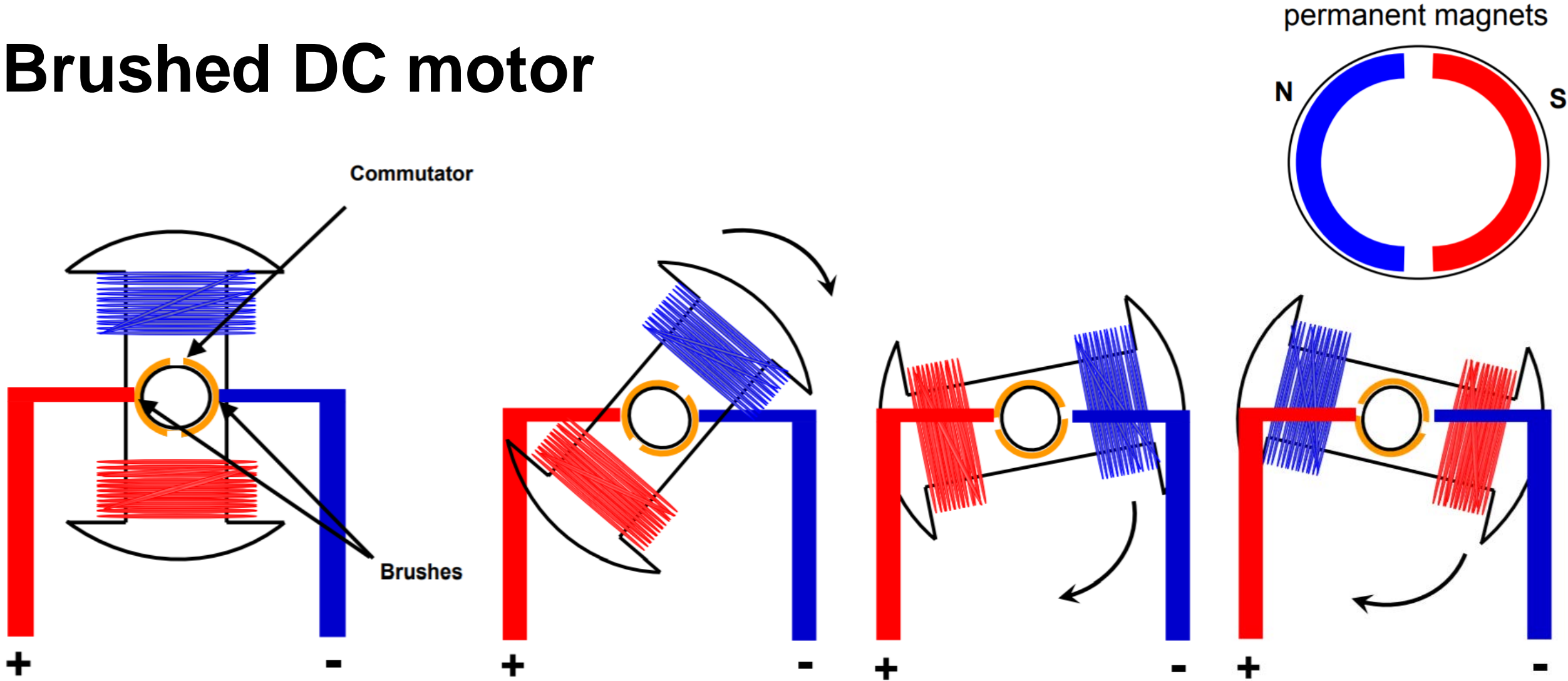

Brushed DC motor

- Standard motors are very fast and very weak
- Gear trains!

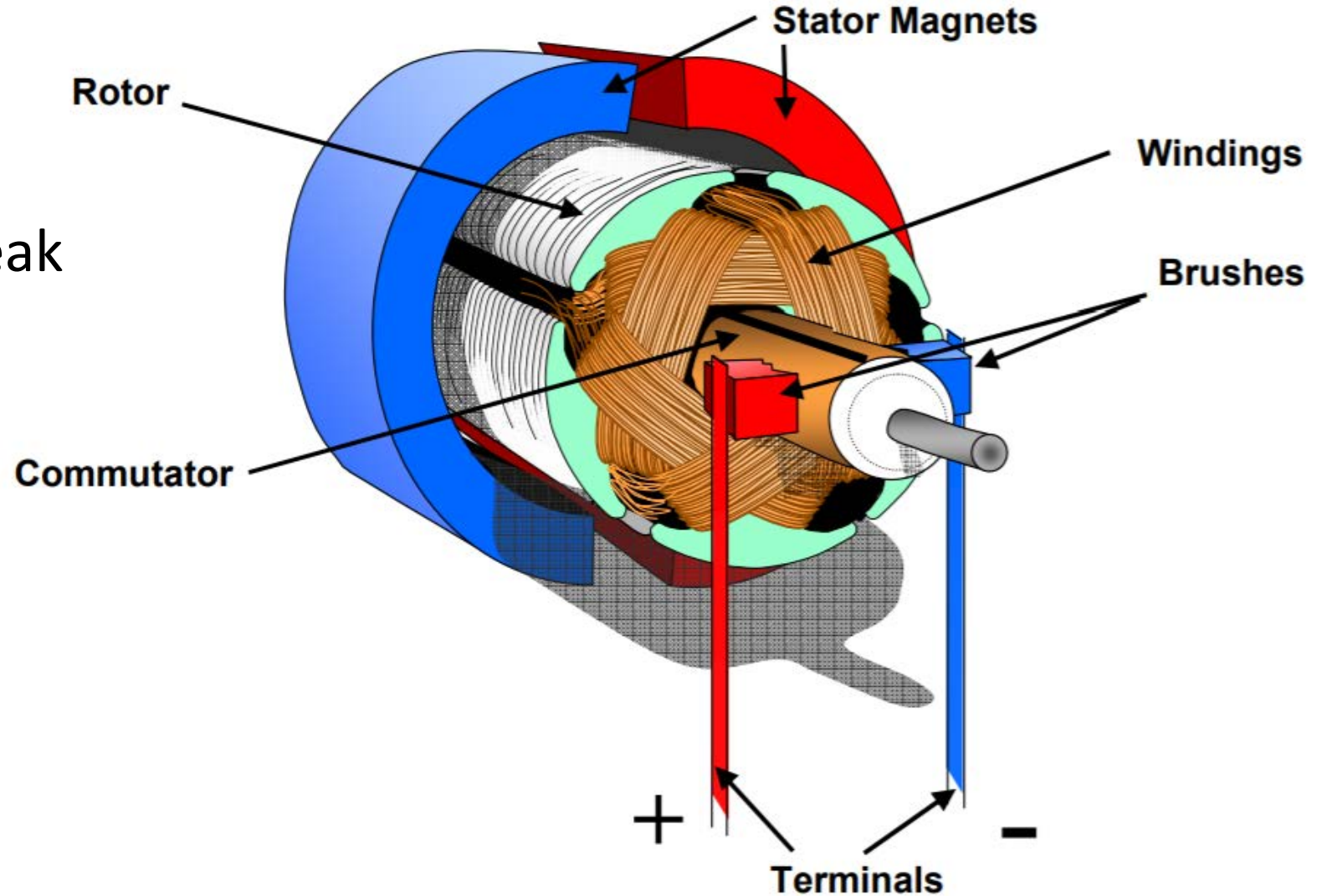

Gear Trains

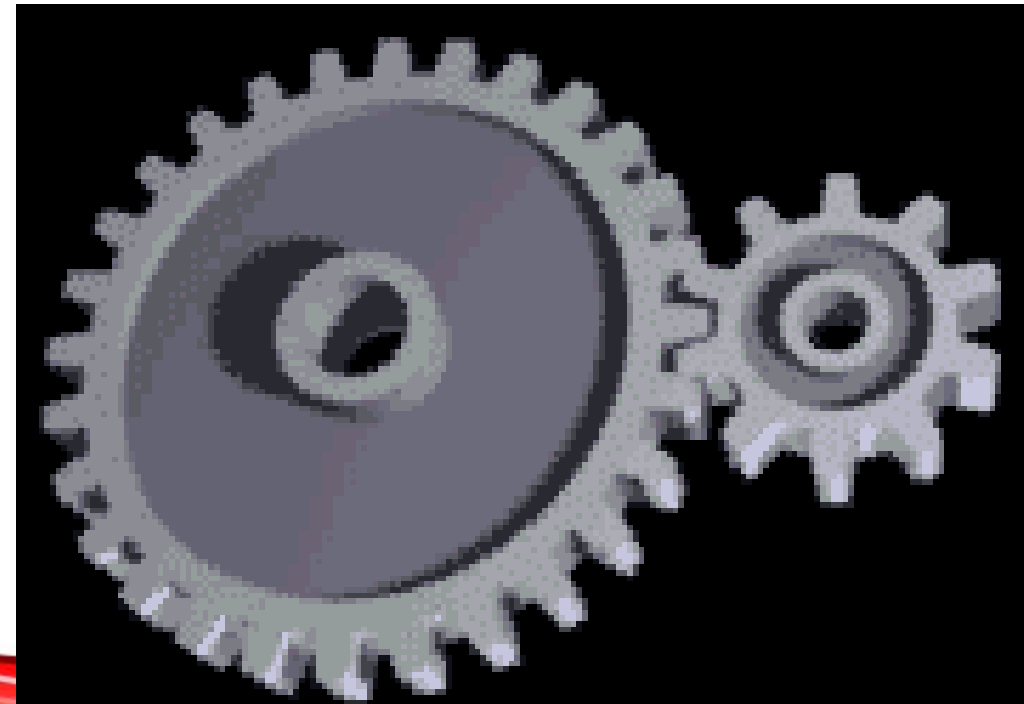
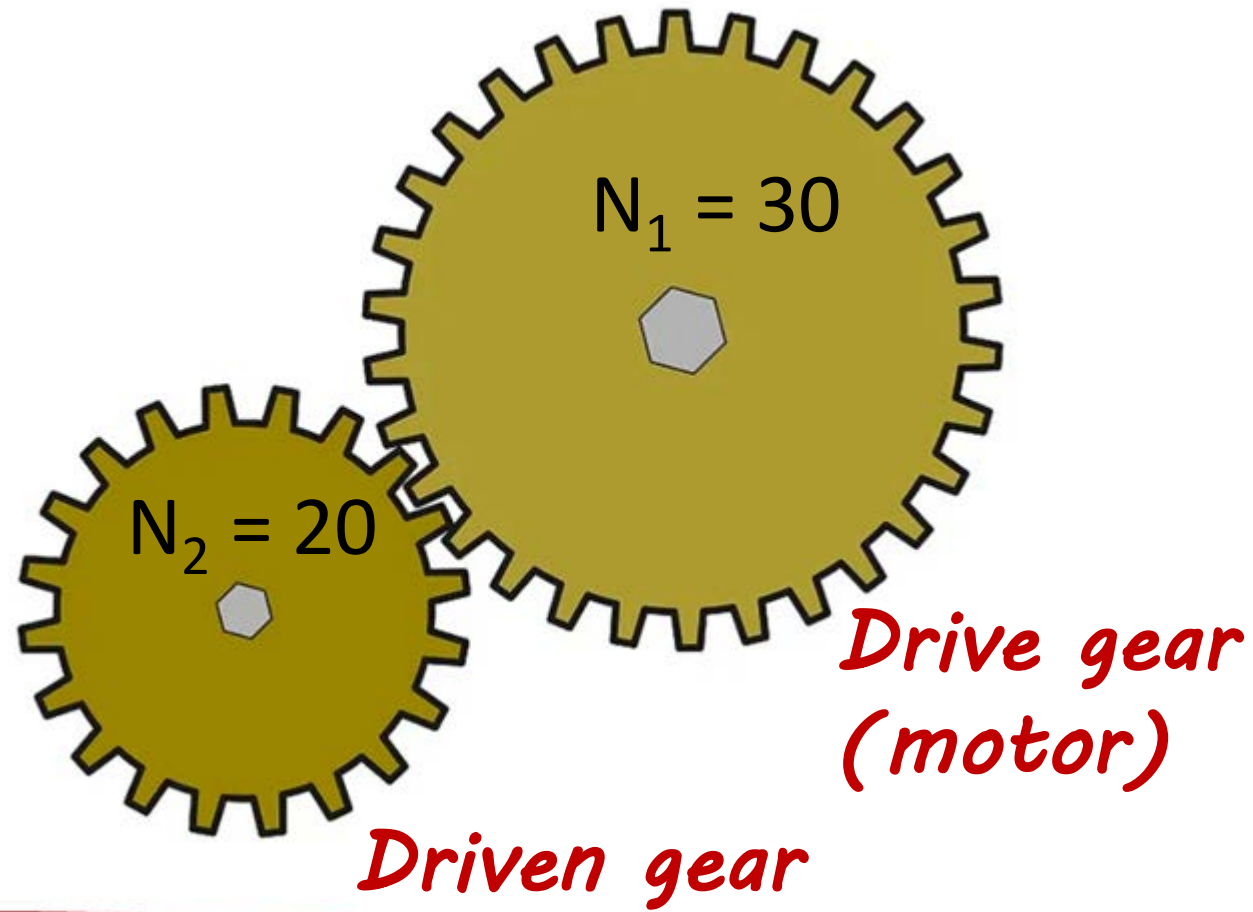

Gear Trains

$$v_2 = v_1 \cdot \frac{N_1}{N_2}$$

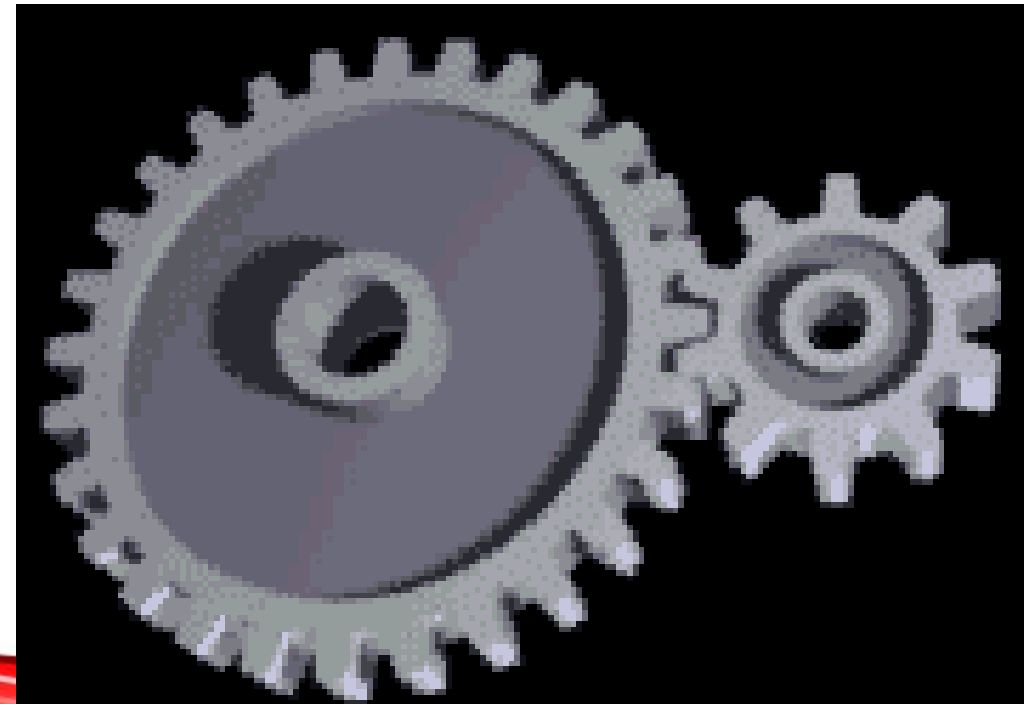
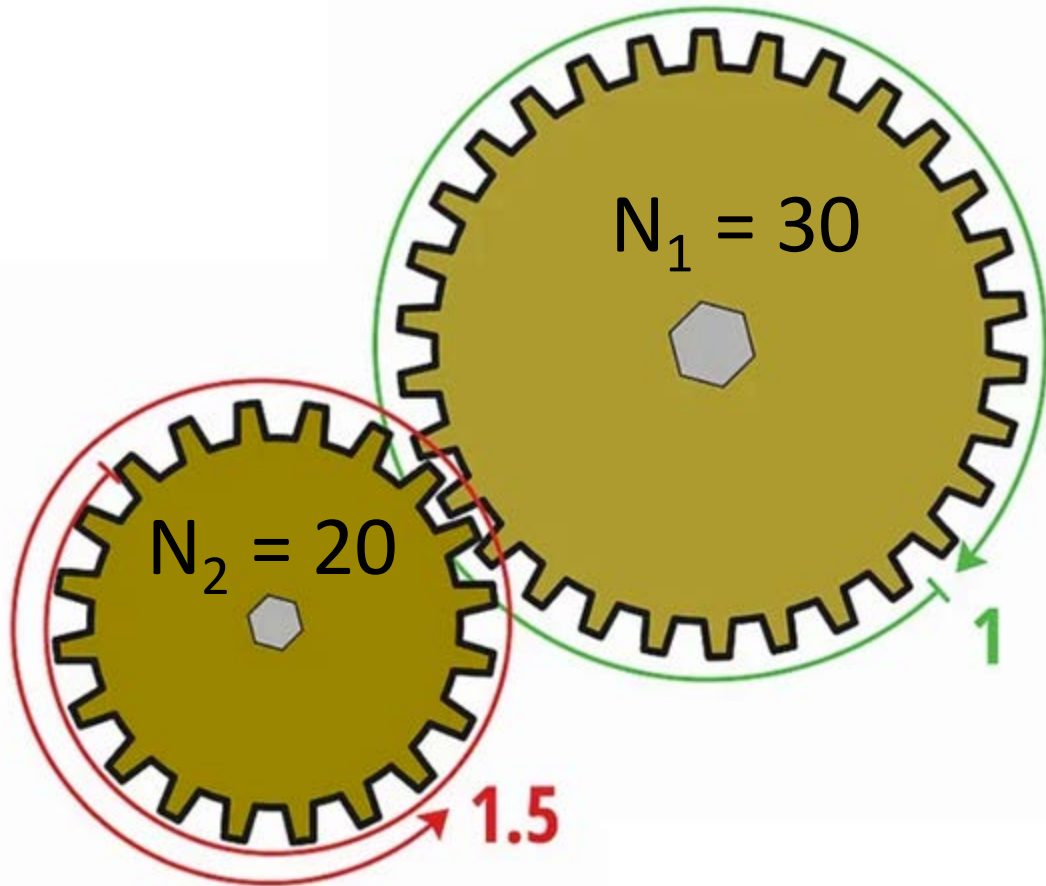

Gear Trains

$$v_3 = v_1 \cdot \frac{N_1}{N_3}$$

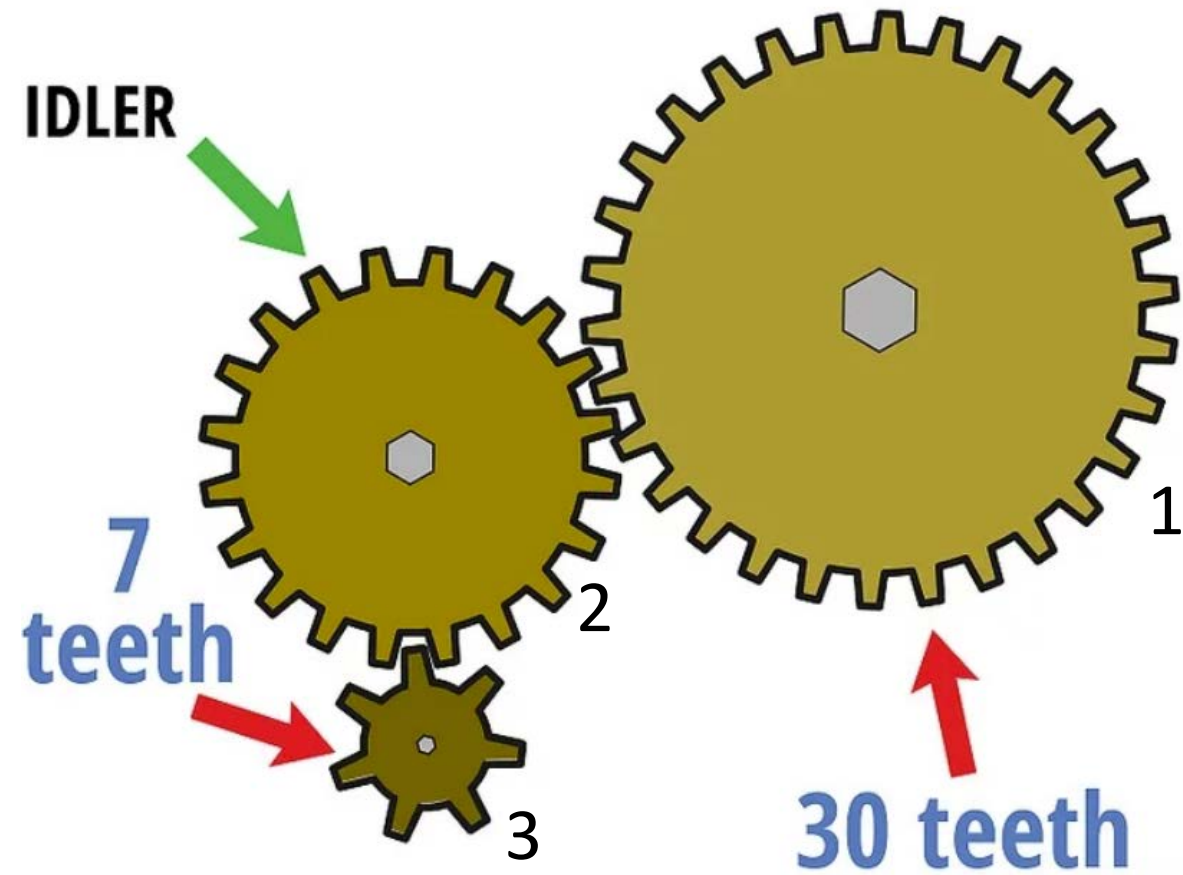

Gear Trains

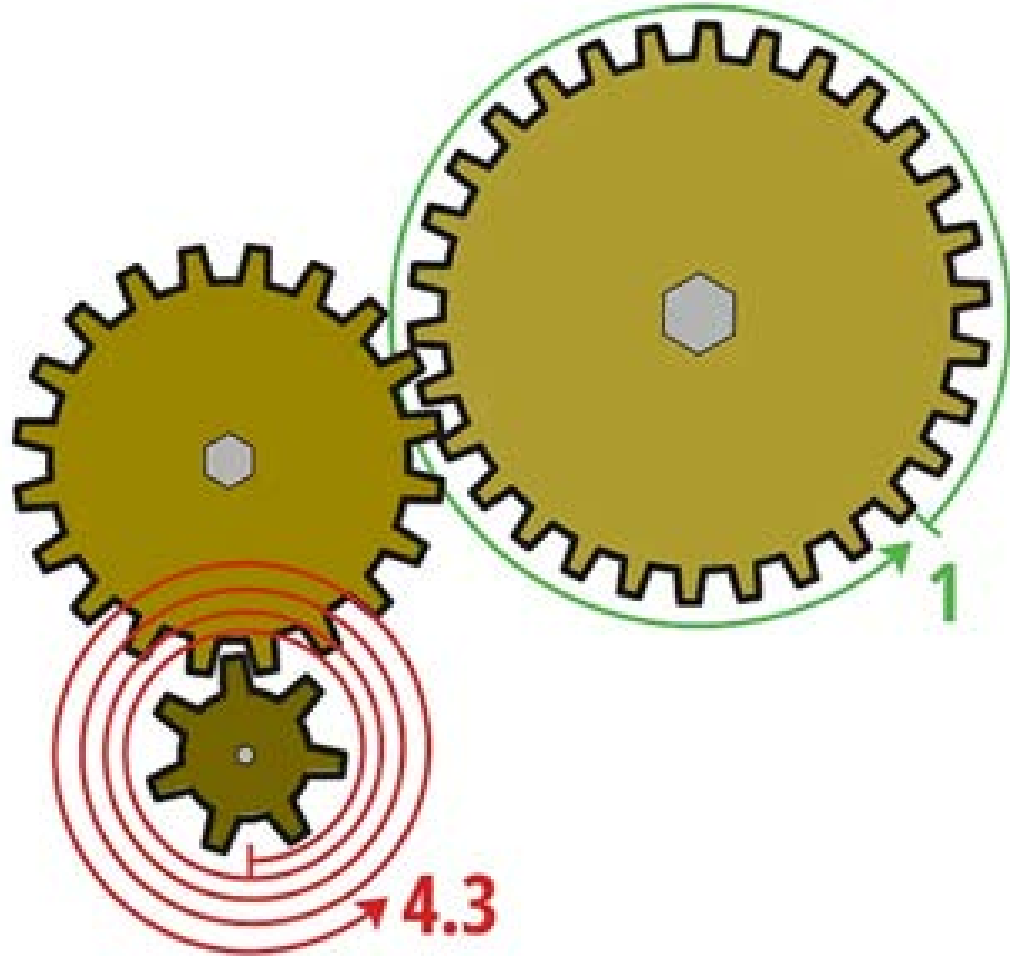

$$v_3 = v_1 \cdot \frac{N_1}{N_3}$$

$$v_3 = v_1 \cdot \frac{N_1}{N_2} \cdot \frac{N_2}{N_3}$$

Gear Trains

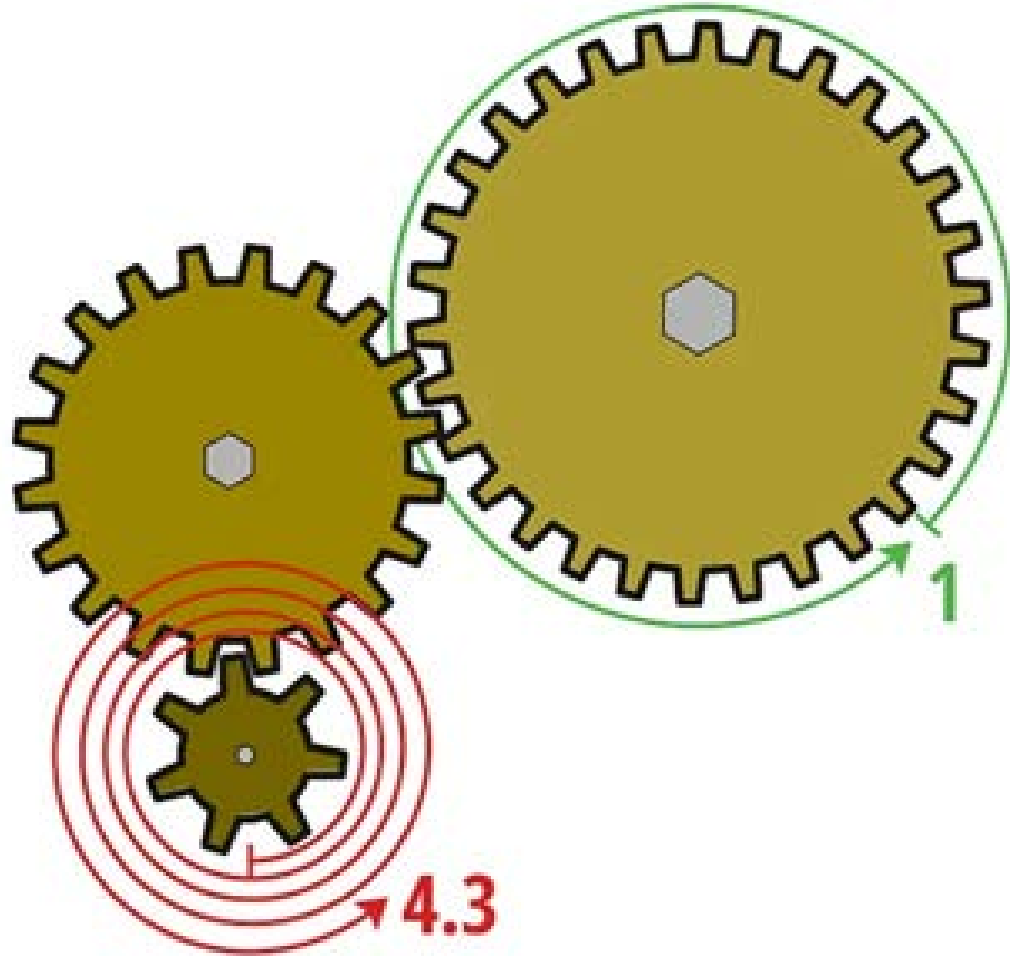

$$v_3 = v_1 \cdot \frac{N_1}{N_3}$$

$$\tau_3 = \tau_1 \cdot \frac{N_3}{N_1}$$

(real gears have loss - rule of thumb: loose ~10% per contact point)

Gear Trains

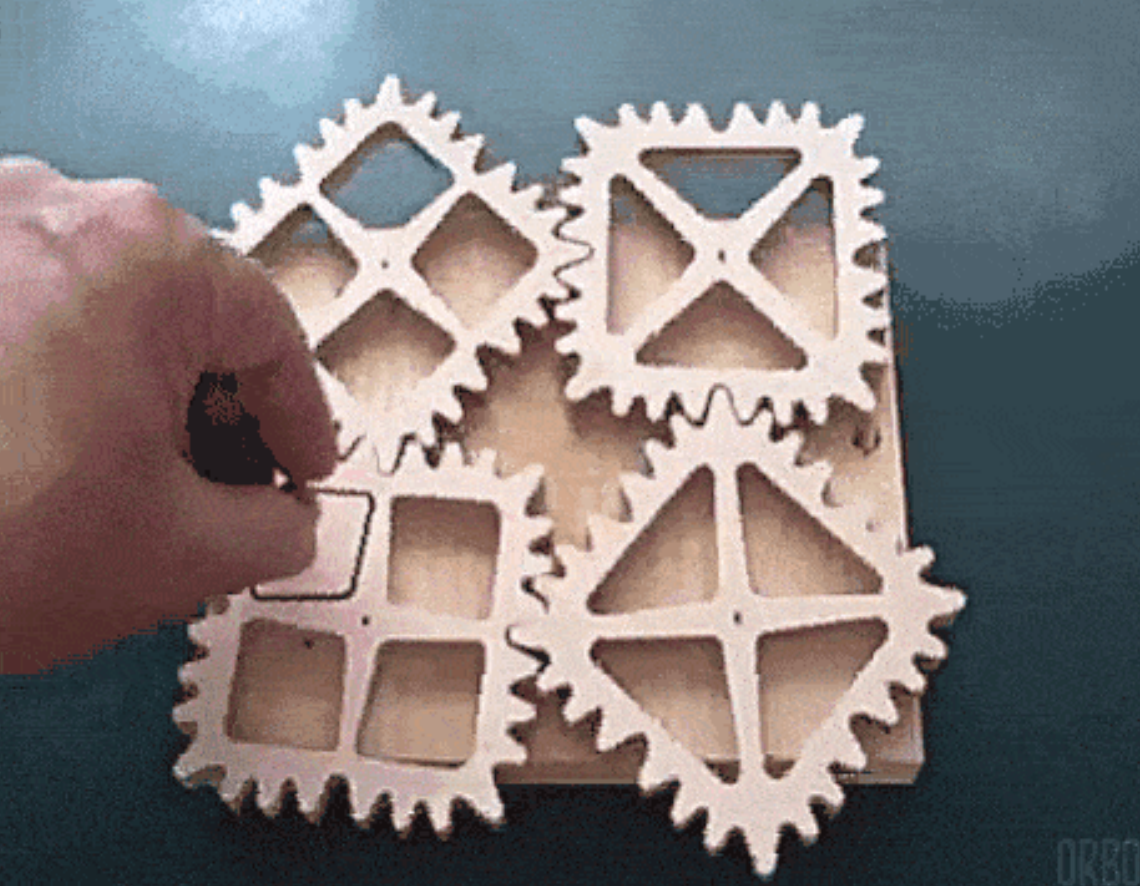
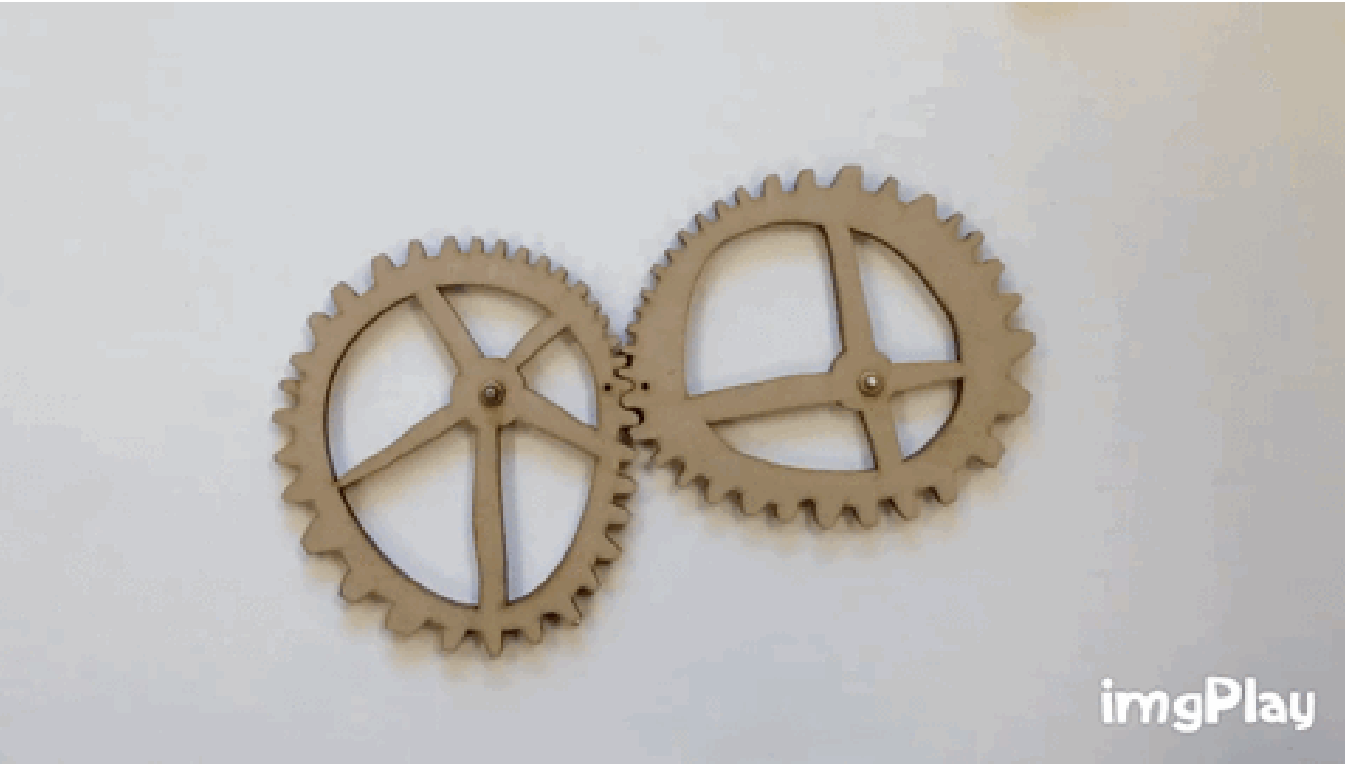

Driving a DC motor



Driving a DC motor

- Analog voltage

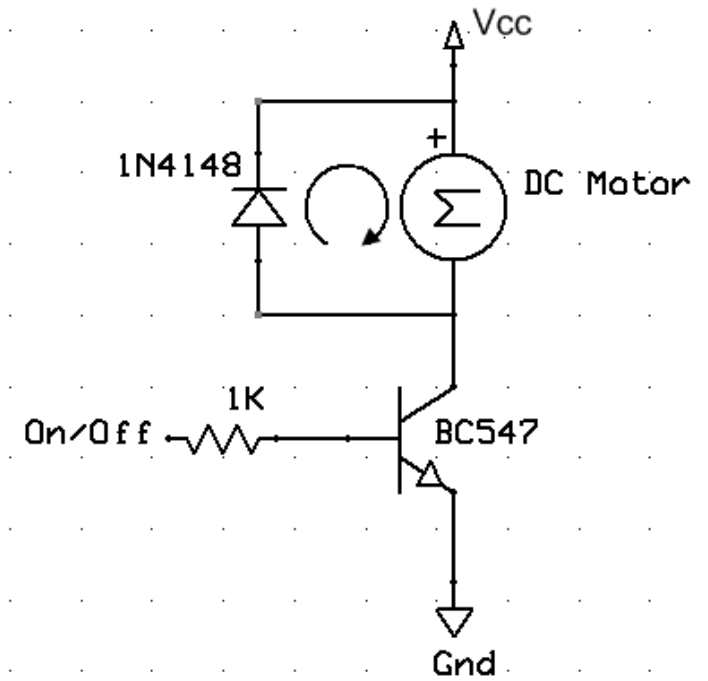
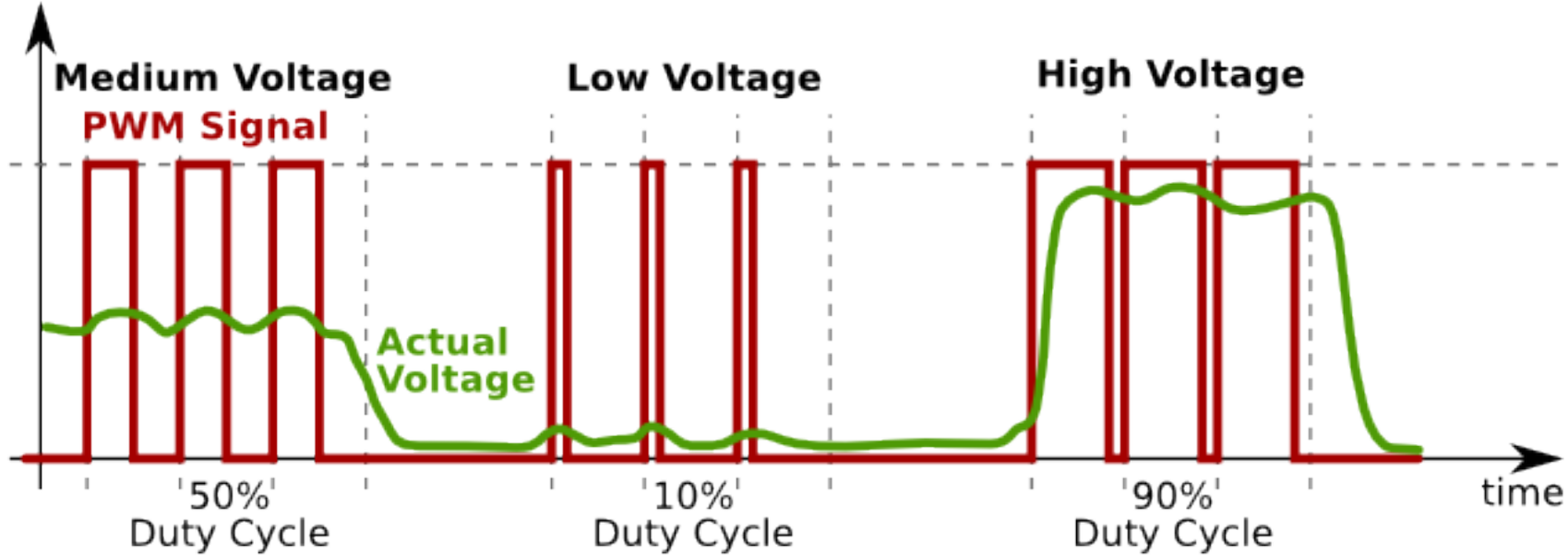

Driving a DC motor

- Analog voltage
- H-Bridge

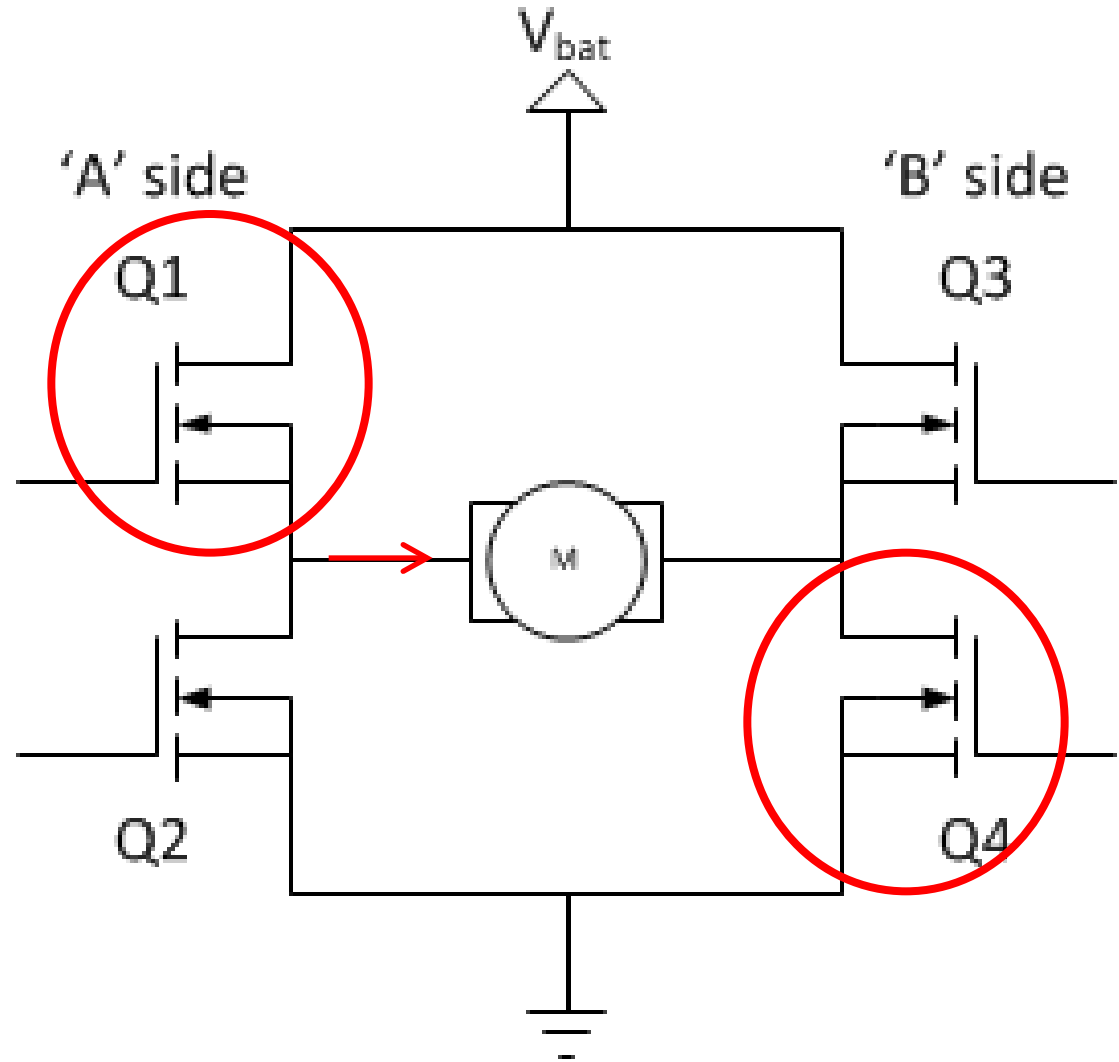

Driving a DC motor

- Analog voltage
- H-Bridge

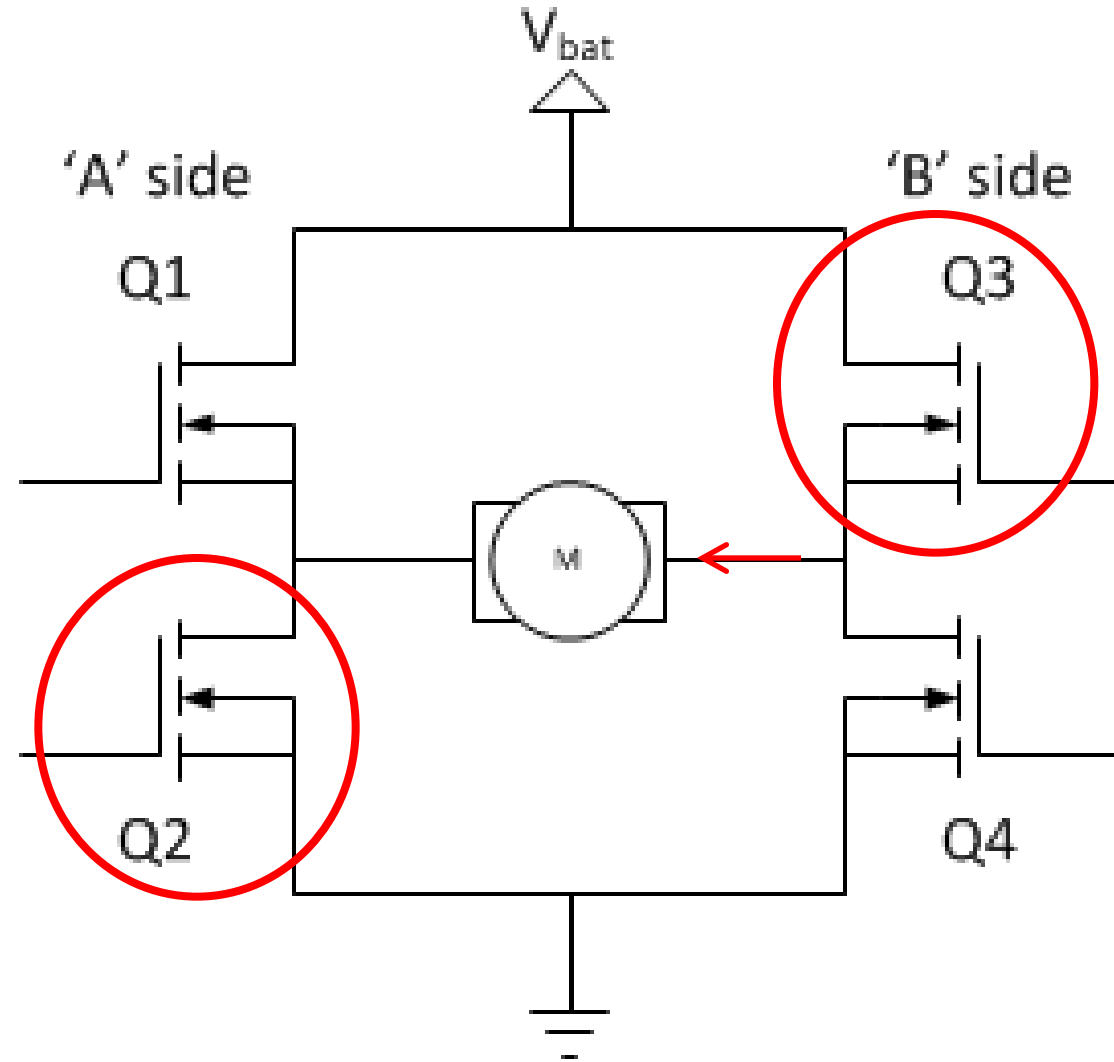

Driving a DC motor

- Analog voltage
- H-Bridge
- Electromotive Force (EMF)

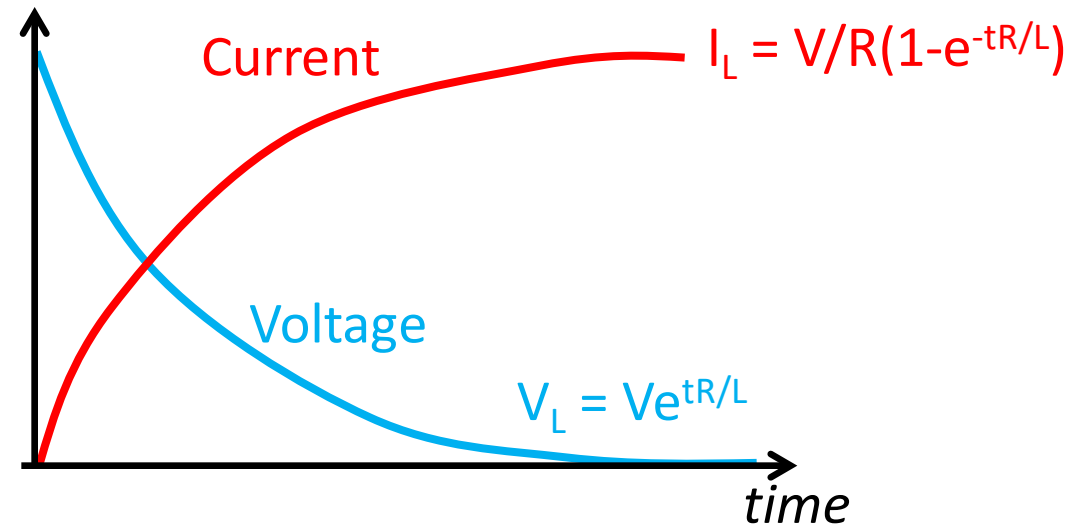
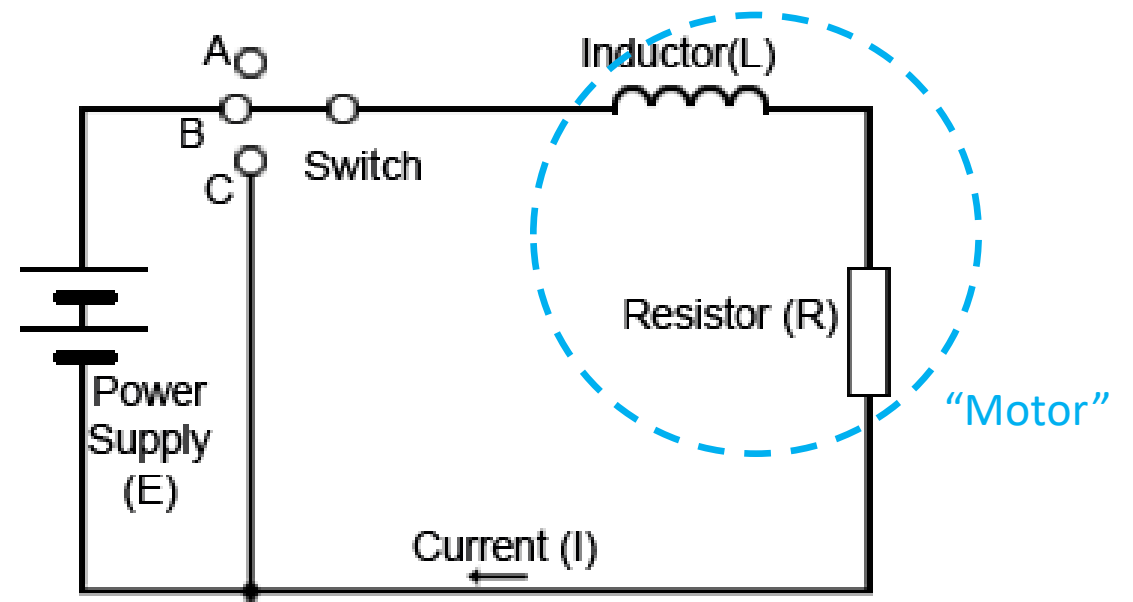

Driving a DC motor

- Analog voltage
- H-Bridge
- Electromotive Force (EMF)

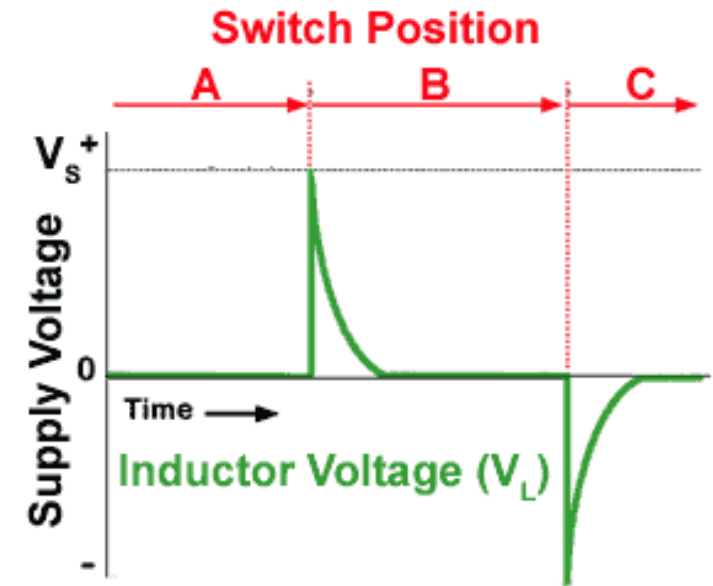
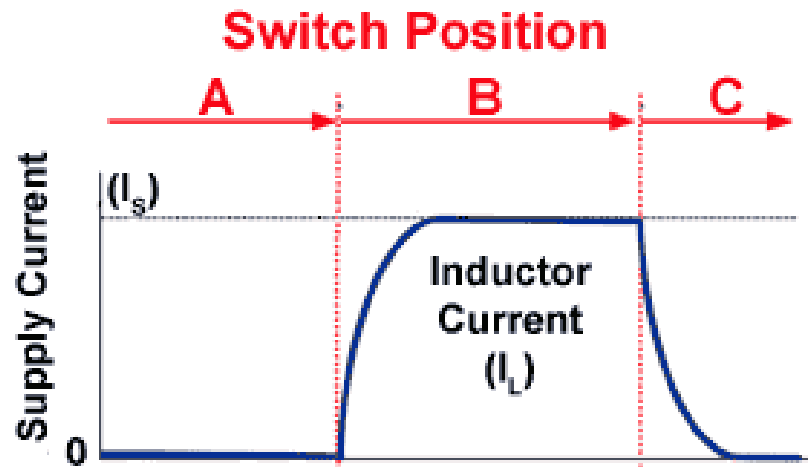
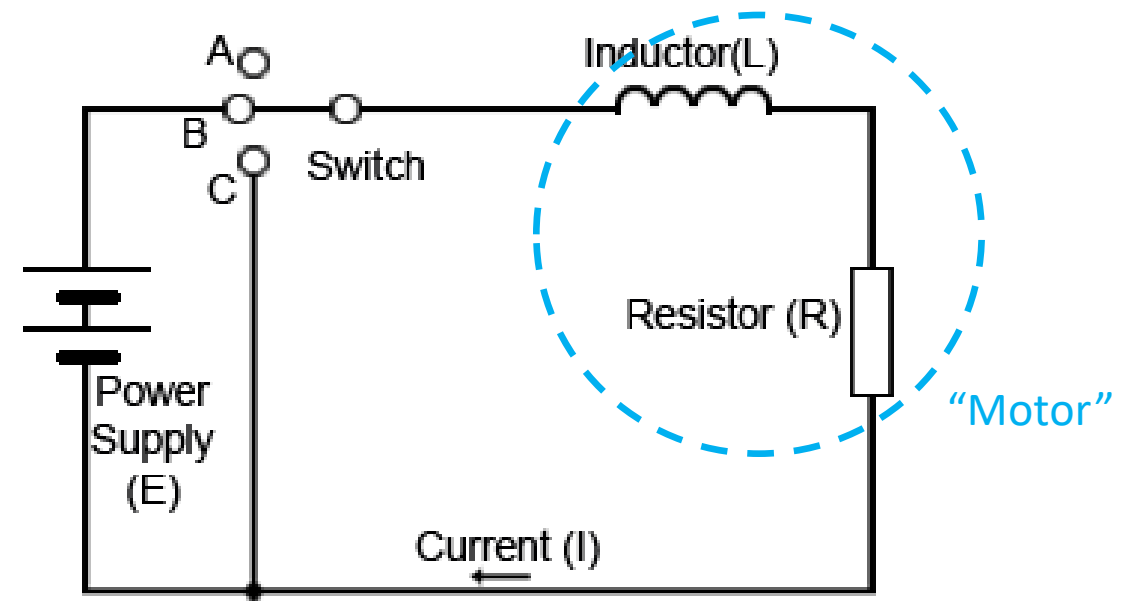

Driving a DC motor

- Analog voltage
- H-Bridge
- Electromotive Force (EMF)

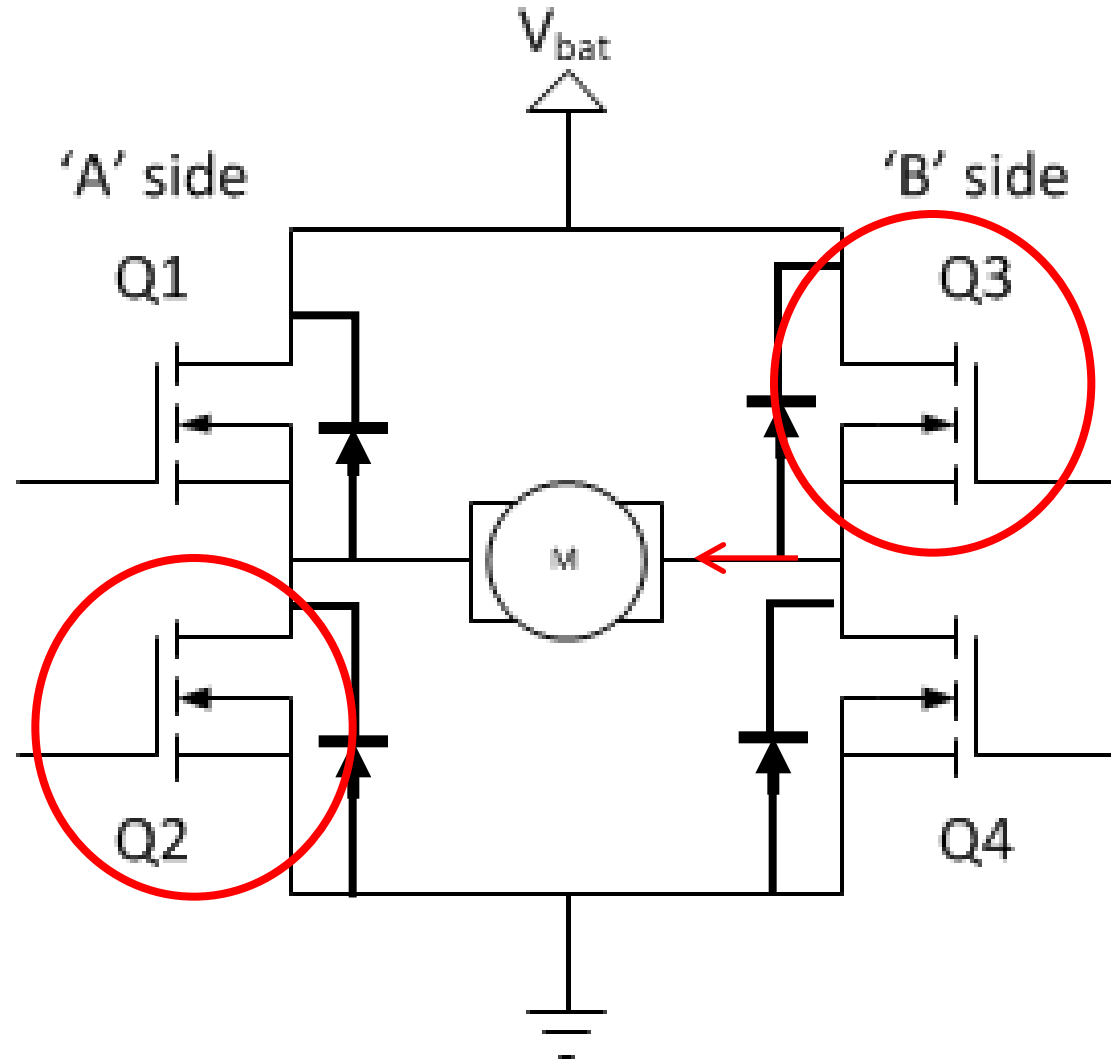

Driving a DC motor

- H-Bridge
- PWM

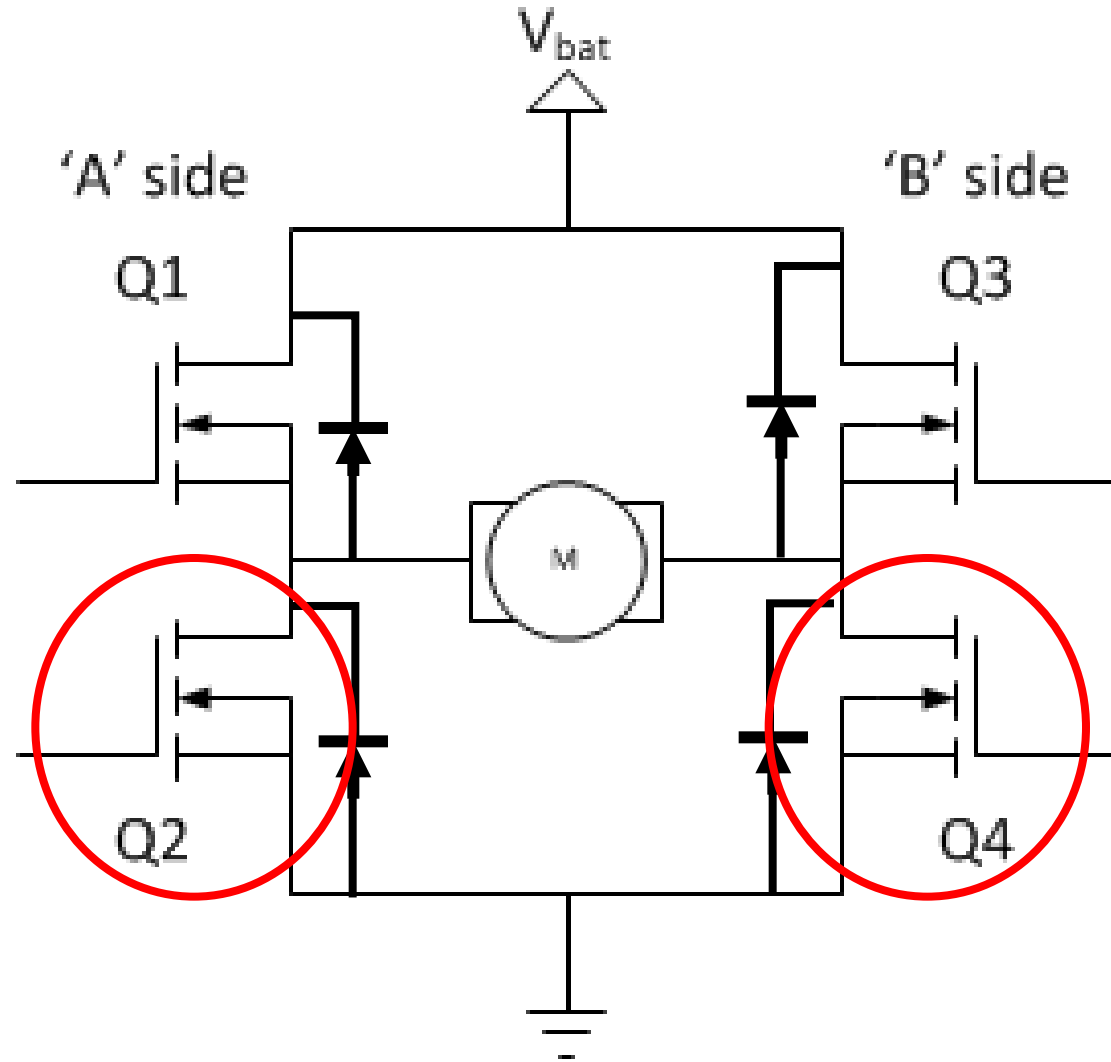

Commercial Vendors

- **Components:** Digikey, Allied, Mouser, Newark, Circuit Specialists
- **Robotics:** Parallax, Lynxmotion, Tower Hobbies, Hobbyking, Sparkfun, Polulu, Jameco, Phidgets
- **Mechanics:** McMaster, Stock Drive Products

Pololu Robotics & Electronics

Log In | Wish Lists | BIG Order Form | Shopping Cart

US toll free: 1-877-7-POLULU ~ (702) 262-6648
Same-day shipping, worldwide

Robotics & Electronics

Search

Feedback

Comments or questions?
(opens in new window)

Services

- Custom Laser Cutting
- SMT Stencils

Products

New Products

Specials!

Robot Kits

- Balboa Robot and Accessories
- Romi Chassis and Accessories
- Zumo Robots and Accessories
- 3pi Robot and Accessories

Zumo

Get a little pushy.

CLICK HERE for more info!

A-Star Zumo 3pi Maestro SMC Wheels Wixel

Robot Kits

Choose from our selection of affordable robot kits with soldering or without. We have various beginner-level kits as well as advanced walking robots, robotic arms, and our high-performance wheeled and tracked robots.

Motors and Gearboxes

Our wide selection of DC motors, geared DC motors, and stepper motors will help you find the perfect blend of torque and speed for your project.

Regulators and Power Supplies

Ensure your project gets the voltage it needs with these voltage regulator boards and wall-adaptor power supplies.

New Products

- FEETECH FT90R Digital Micro Continuous Rotation Servo
- Pololu Universal Aluminum Mounting Hub for 8mm Shaft, M3 Holes (2-Pack)
- Tic T825 USB Multi-Interface Stepper Motor Controller
- Tic T825 USB Multi-Interface Stepper Motor Controller (Connectors Soldered)

SparkFun Electronics

Find a Retailer Need Help?

sparkfun START SOMETHING

SHOP LEARN BLOG SUPPORT

PRODUCT MENU find products, tutorials, etc.

EDUCATION AVC FORUM DATA

SparkFun AVC 2017

PRIZES HAVE BEEN ANNOUNCED!

3D printers for students,
Playstation 4 VR rigs for adults!

SEE ALL AWARDS

New Products

See All

PAGE 1 OF 6

Phidgets

Products for USB Sensing and Control

Create Account | Sign In

SEARCH BY PHIDGETS ITEM CODE

PHIDGETS SENSORS MECHANICAL OTHER SUPPORT

CATEGORIES

Phidgets

11 PRODUCTS FOUND

Phidgets

All Phidgets

I/O Boards

Relays

SBC

Adapters

Motor Controllers

Remote Control

RFID

Go Build Robots!

